

LUBRICATE ALL SEALS WITH CLEAN HYDRAULIC OIL PRIOR TO ASSEMBLY.
DO NOT USE SILICONE BASED LUBRICANTS.

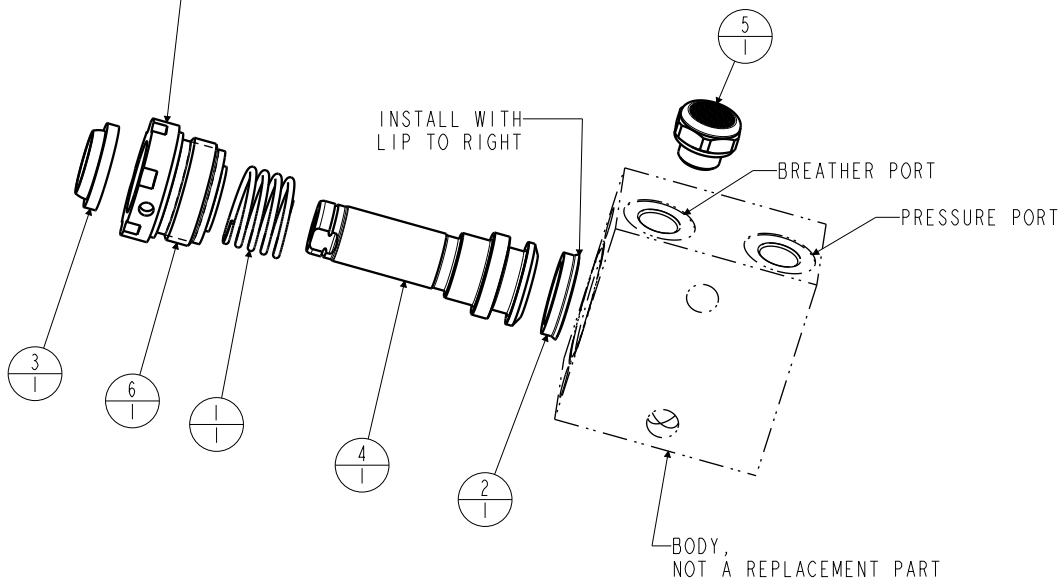

TIGHTEN TO 75 Nm TORQUE (55 FT-LBS)
USE VEKTEK TORQUE TOOL
NEW STYLE TORQUE TOOL AT200081, 6 POINTED TOOL (CIRCA 2018)
OLD STYLE TORQUE TOOL AT200080, 2 POINTED SPANNER HOLE TOOL



N/A	N/A	46100025	KIT, SPRING	N/A	N/A	NOTED
N/A	N/A	6V201108	KIT, SEAL, FKM	N/A	NOTED	N/A
N/A	N/A	46000035	KIT, SEAL, STANDARD	NOTED	N/A	N/A
6	1	82030802	GLAND, CYL, BB, DA, 2200			
5	1	49001904	BREATHER, 1/8 BSPP			
4	1	48010802	PISTON, CYL, BB, 10.1KN, 6.5 STRK			
3	1	39012011	WIPER, SNAP-IN, (1/2)	X	X	
2	1	39010013	SEAL, BEVEL, 9/16 X 3/32 X 3/4	X	39012000	
1	1	23313007	SPRING, COMPRESSION			X
No.	QTY	PART No.	DESCRIPTION	Standard Seal Kit	FKM Seal Kit	Spring Kit

PARTS LIST



VEKTEK, INC.
1334 E. SIXTH AVE. P.O. BOX 625
EMPORIA, KS. 66801 U.S.A.

ASSEMBLIES AFFECTED
42011000

PARTS LIST, ASSY, CYL, BB, 10,1KN, 6,5 STRK, SA

SIZE A
MPL2043

REV H

SHEET 1 OF 1

H	4249	RELEASE	JDW	08/03/20
REV	IN ACCORDANCE WITH ECN	EFFECTIVE DATE	REVISED BY	DATE
DRW BY:	BUSH	DRAWING STATUS: Released		
DATE:	12/15/94	PRODUCTION APPROVED FOR RELEASED STATUS ONLY		

FORM FEG035_PL.A.SIZE, REV. B